

95 ³/₄"
(7' 11 ³/₄")

227 ¹/₂"
(18' 11 ¹/₂")

131 ¹/₂"
(10' 11 ¹/₂")



95 ³/₄"
(7' 11 ³/₄"

131 ¹/₂"
(10' 11 ¹/₂"

227 ¹/₂"
(18' 11 ¹/₂"



Column
Height
95 ³/₄"
(7' 11 ³/₄"

(+/- 2"
Depending on
Thread
Adjustment
and Floor
Pitch)

80 ¹/₄"
(6' 8 ¹/₄"
Below
Runway

85"
(7' 1")
To Top
of Runway

123 ¹/₂" (10' 3 ¹/₂" Without Motor





95 ³/₄"
(7' 11 ³/₄"

227 ¹/₂" (18' 11 ¹/₂" Overall Length With Approach Ramps

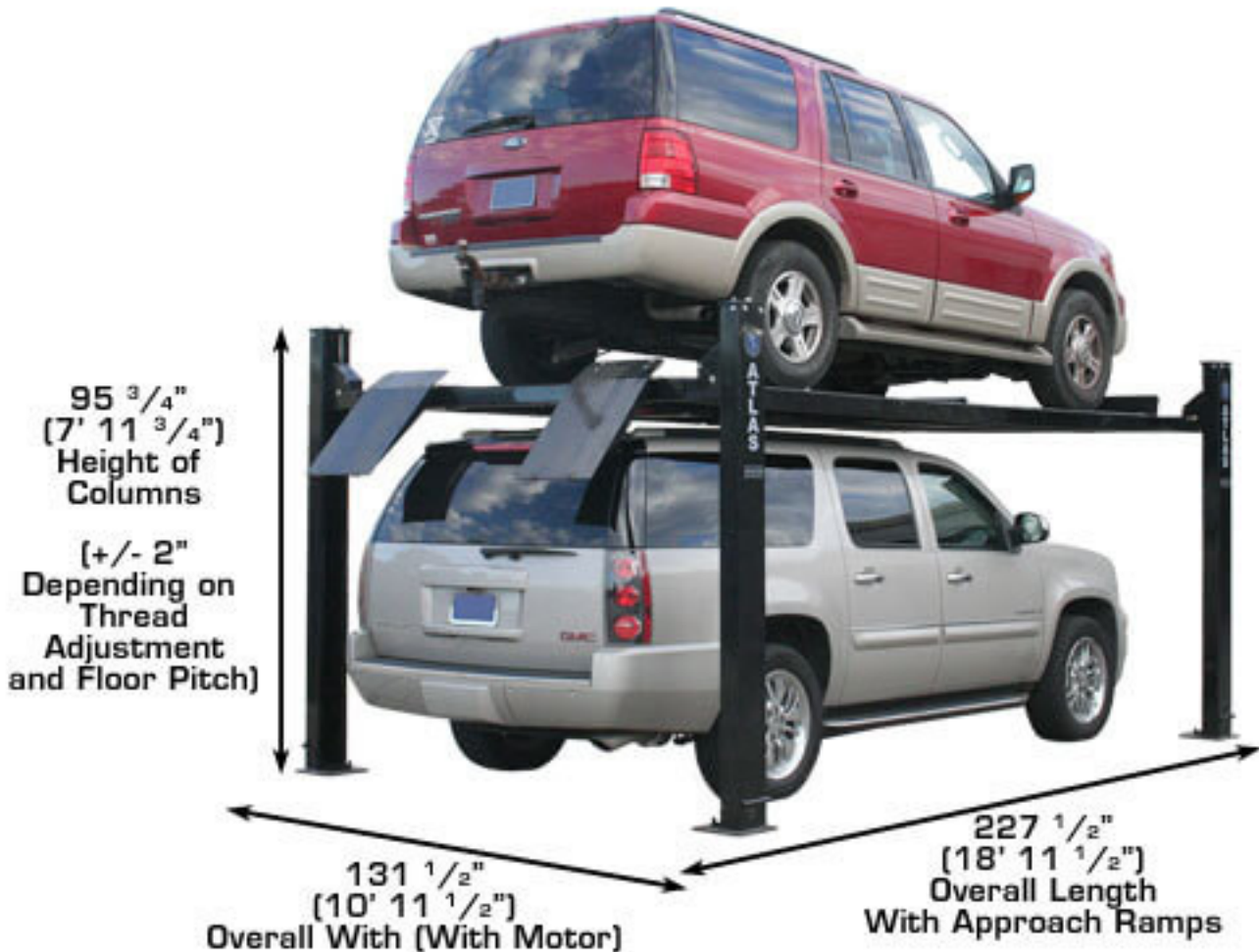

95 $\frac{3}{4}$ "
(7' 11 $\frac{3}{4}$ "
Column
Height

80 $\frac{1}{4}$ "
(6' 8 $\frac{1}{4}$ "
Below
Runway

85"
(7' 1")
Top Of
Runway

131 $\frac{1}{2}$ "
(10' 11 $\frac{1}{2}$ "
Width With Motor

227 $\frac{1}{2}$ "
(18' 11 $\frac{1}{2}$ "
Length With Ramps

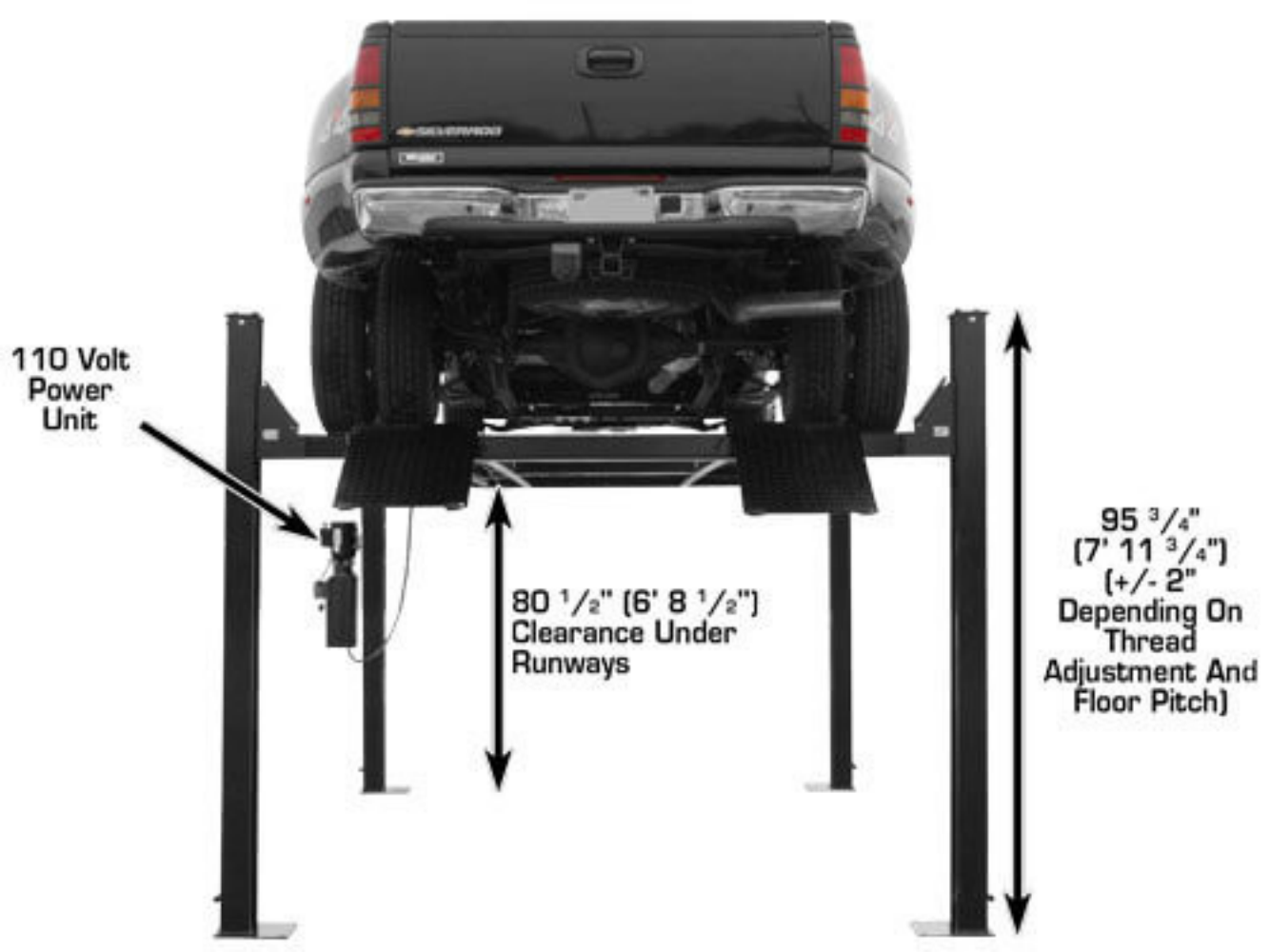

110 Volt
Power
Unit

80 1/2" (6' 8 1/2")
Clearance Under
Runways

95 3/4"
(7' 11 3/4")
(+/- 2"
Depending On
Thread
Adjustment And
Floor Pitch)

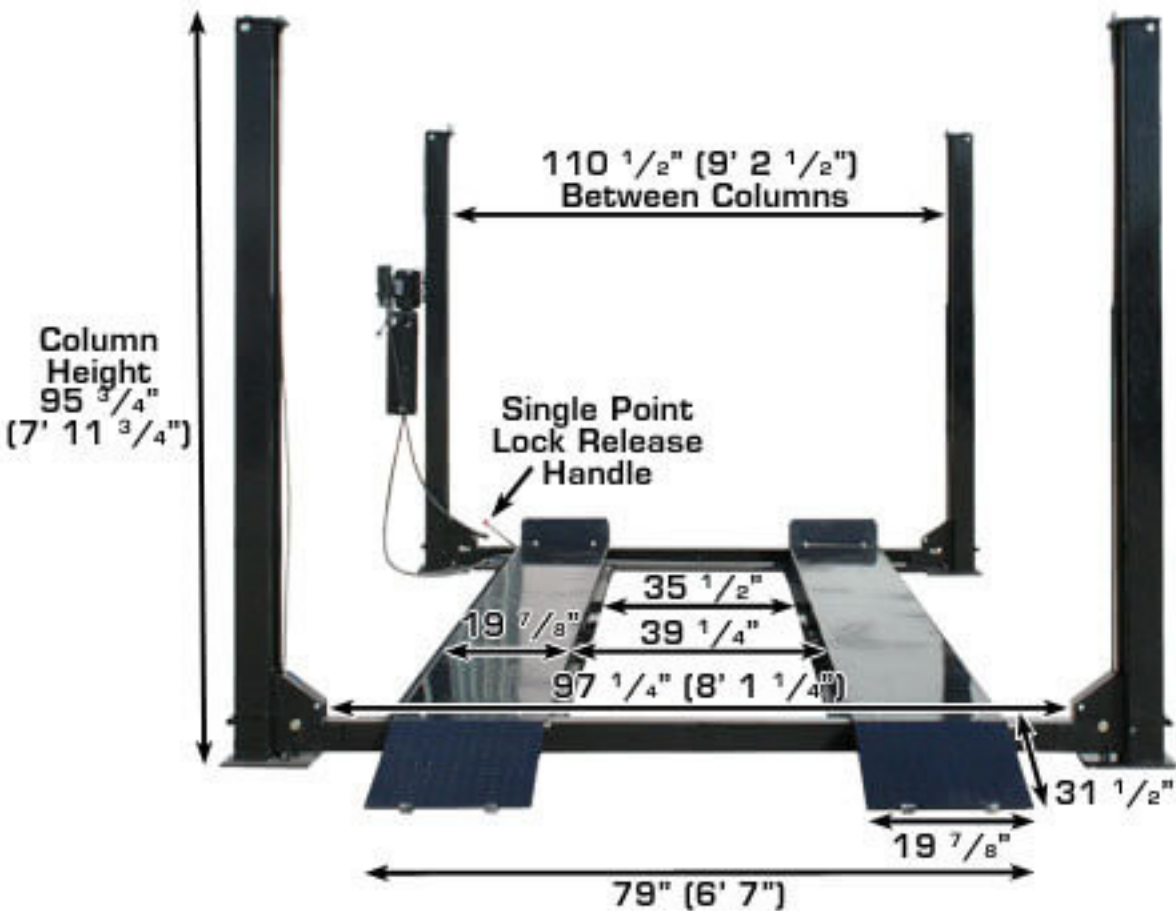





**.4375" ($\frac{7}{16}$ "
Cable Diameter**

**3 $\frac{1}{2}$ "
Diameter
Cylinder**

**6"
Steel Pulleys**

$7/16$ " Cable
Diameter

1.1875" Ram
Diameter

3 $1/2$ " Cylinder
Diameter

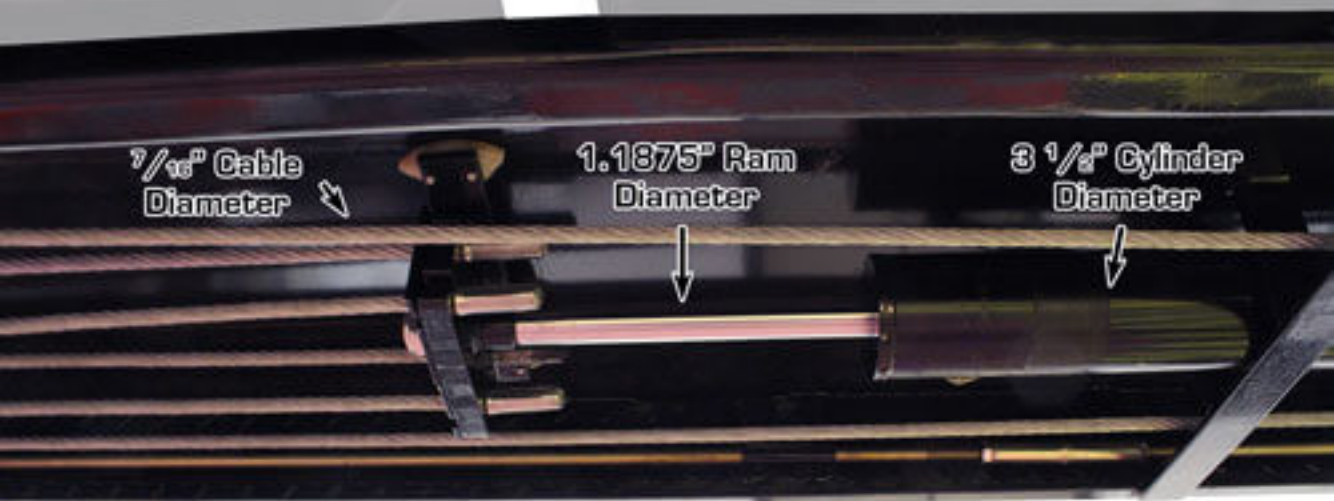

Cylinder Flow Restrictor Valve -

This valve automatically decreases the lowering speed in case of a burst hydraulic line. Of course, the locks will automatically engage at the next lower lock position. However, we added this valve to decrease the lowering speed by 50%.



Power Switch

110 Volt Motor

Hydraulic
Dump Valve

Pump

Hydraulic
Fluid Reservoir

110 Volt
Power Cord

Metal Braided
Hydraulic Hose

Motor May Vary from Picture Shown

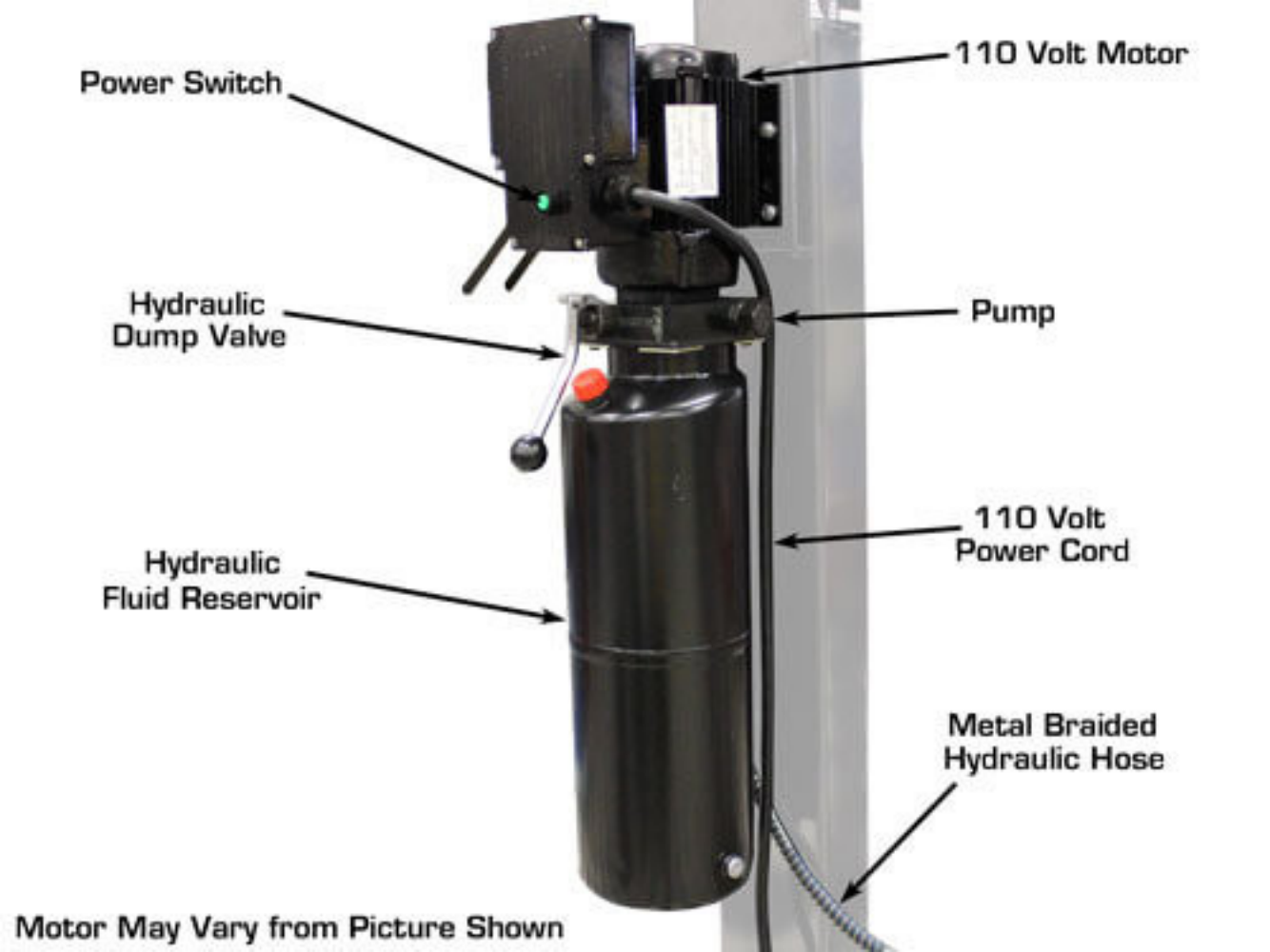

110 Volt Motor

110 Volt
Power Cord

Power Switch

Pump

PN CODE N VOLT 110
PN 480 45 TORRINO PROTECT
MCC P/N
SOLTY PRODUCTS, INC. OF PNW 440 8P 3.1
PN IN 487 10
WARNING: NEVER WORK ON ELECTRICAL SYSTEMS
UNLESS YOU ARE A LICENSED ELECTRICIAN
OR QUALIFIED PERSONNEL

20107839



Caster Kit
Extension

Polyurethane
Wheels

Caster Kit is
Removable

Weight Of Runways On
Caster Kit Extensions
Will Lift All Four Columns
(Less Than 1") Off The Floor.
The Lift Will Then Roll Easily
On The Four Poly Casters.

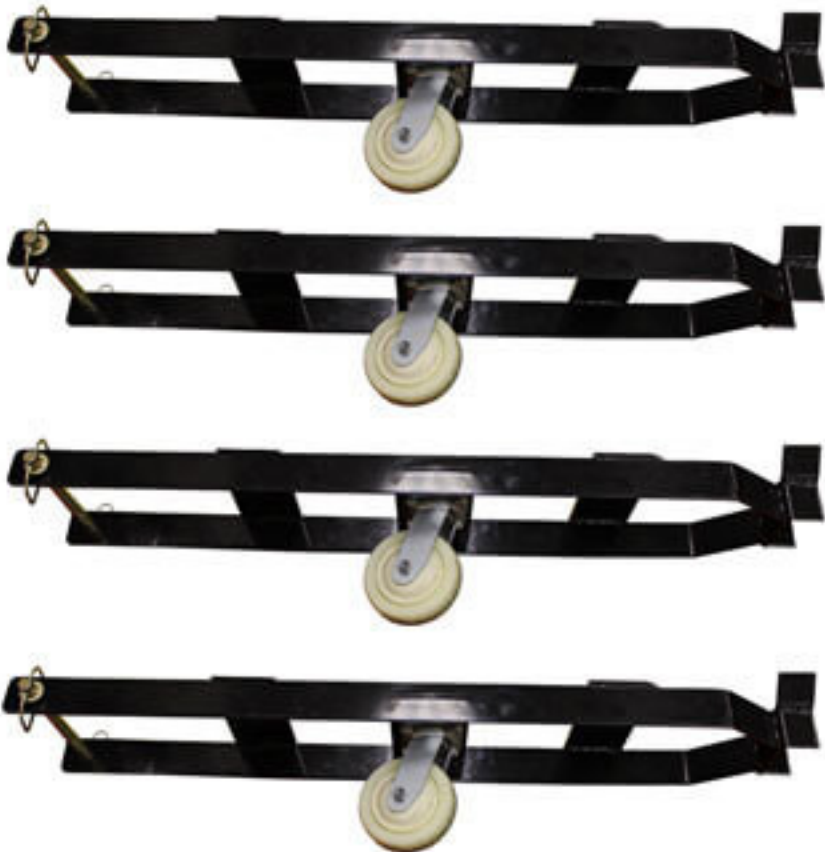

Included Caster Kit With Polyurethane Wheels

Do NOT Move Your Lift With A Vehicle On The Runway



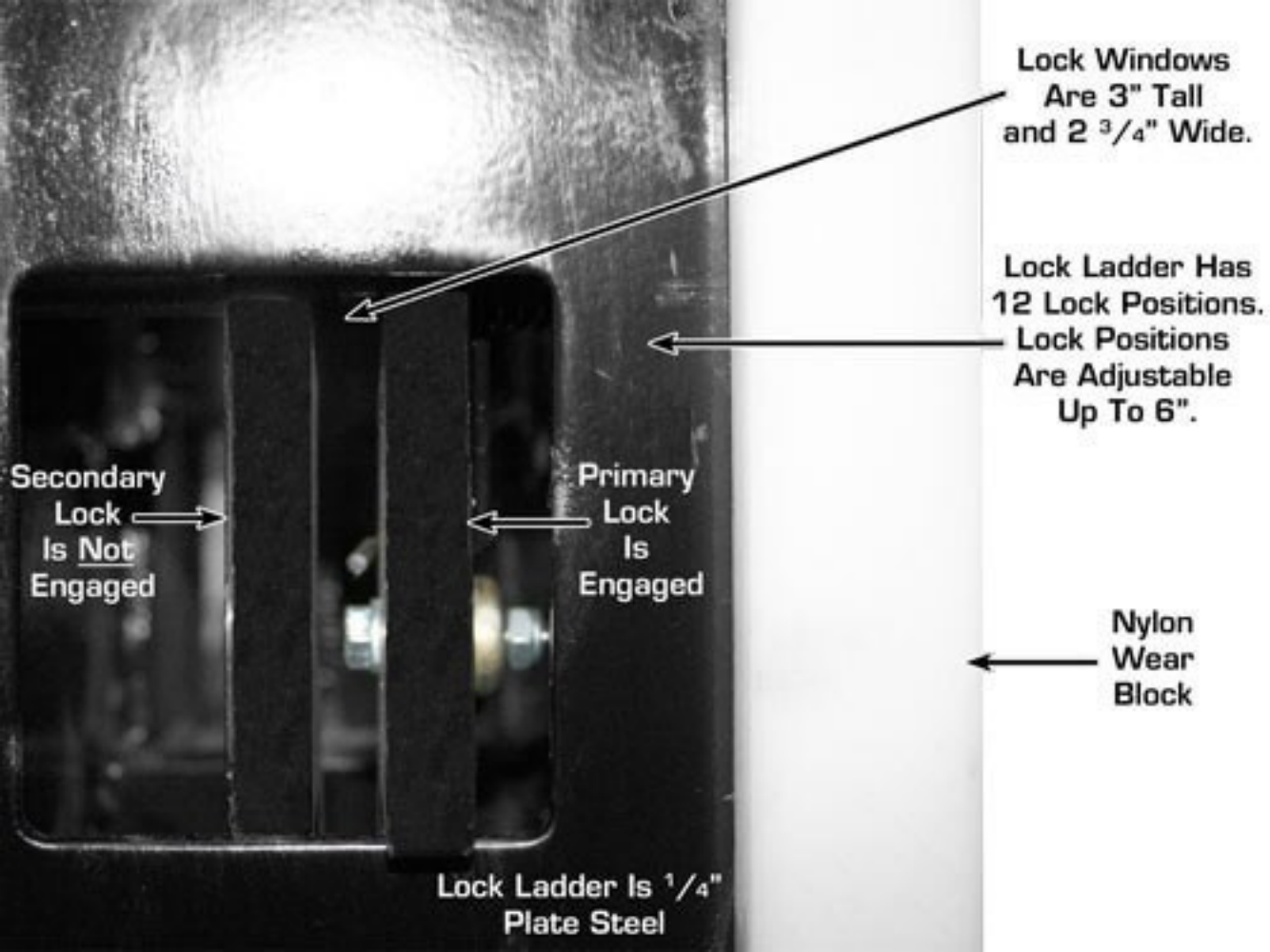

Lock Windows
Are 3" Tall
and 2 3/4" Wide.

Lock Ladder Has
12 Lock Positions.
Lock Positions
Are Adjustable
Up To 6".

Secondary
Lock
Is Not
Engaged

Primary
Lock
Is
Engaged

Nylon
Wear
Block

Lock Ladder Is 1/4"
Plate Steel

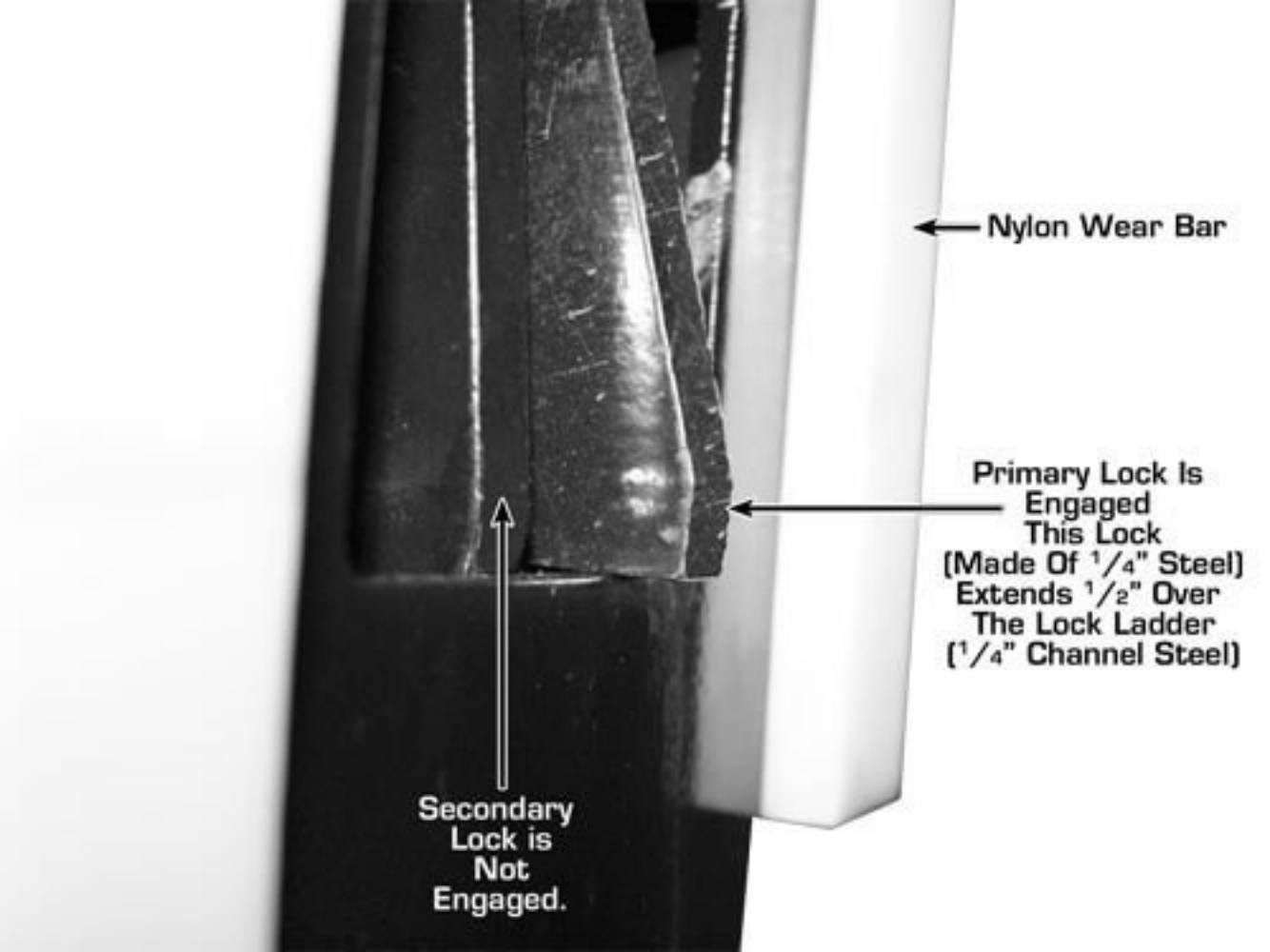

← Nylon Wear Bar

The image shows a close-up of a mechanical lock assembly. A dark, textured metal component is partially inserted into a slot. To its right is a white, cylindrical component. Labels with arrows point to these components. The white component is labeled as the 'Nylon Wear Bar'. The dark component is labeled as the 'Primary Lock', which is engaged. A secondary lock mechanism is also visible, labeled as 'Not Engaged'.

Primary Lock Is Engaged
This Lock
(Made Of $\frac{1}{4}$ " Steel)
Extends $\frac{1}{2}$ " Over
The Lock Ladder
($\frac{1}{4}$ " Channel Steel)

Secondary
Lock is
Not
Engaged.

Polyethylene
Slider Blocks



Cable Rides
Between Large
Steel Pulley And
Smaller Nylon Pulley



Nylon Pulley



Tension Springs



Steel Pulley
Assembly



Cross Beam



Cable Adjustment
Nut/Screw Needed
To Level Runways

Lock Ladder
Adjustment
Nut/Screw

Top Column Plate
Is Designed So
The Column Cables
Hang Outside
Of The Column

$\frac{5}{8}$ " Thick
Plate Steel

$\frac{7}{16}$ " Thick
Steel Cable

Lock Ladder Has
11 Locking Positions

5 Gauge
(.2" / 5mm)
Steel Column

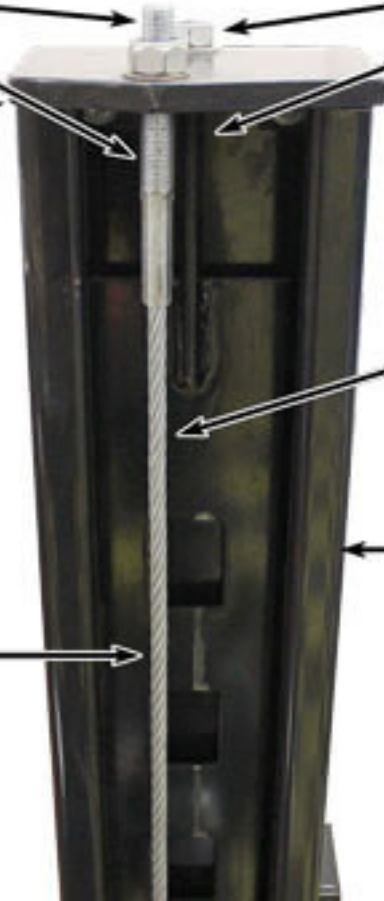

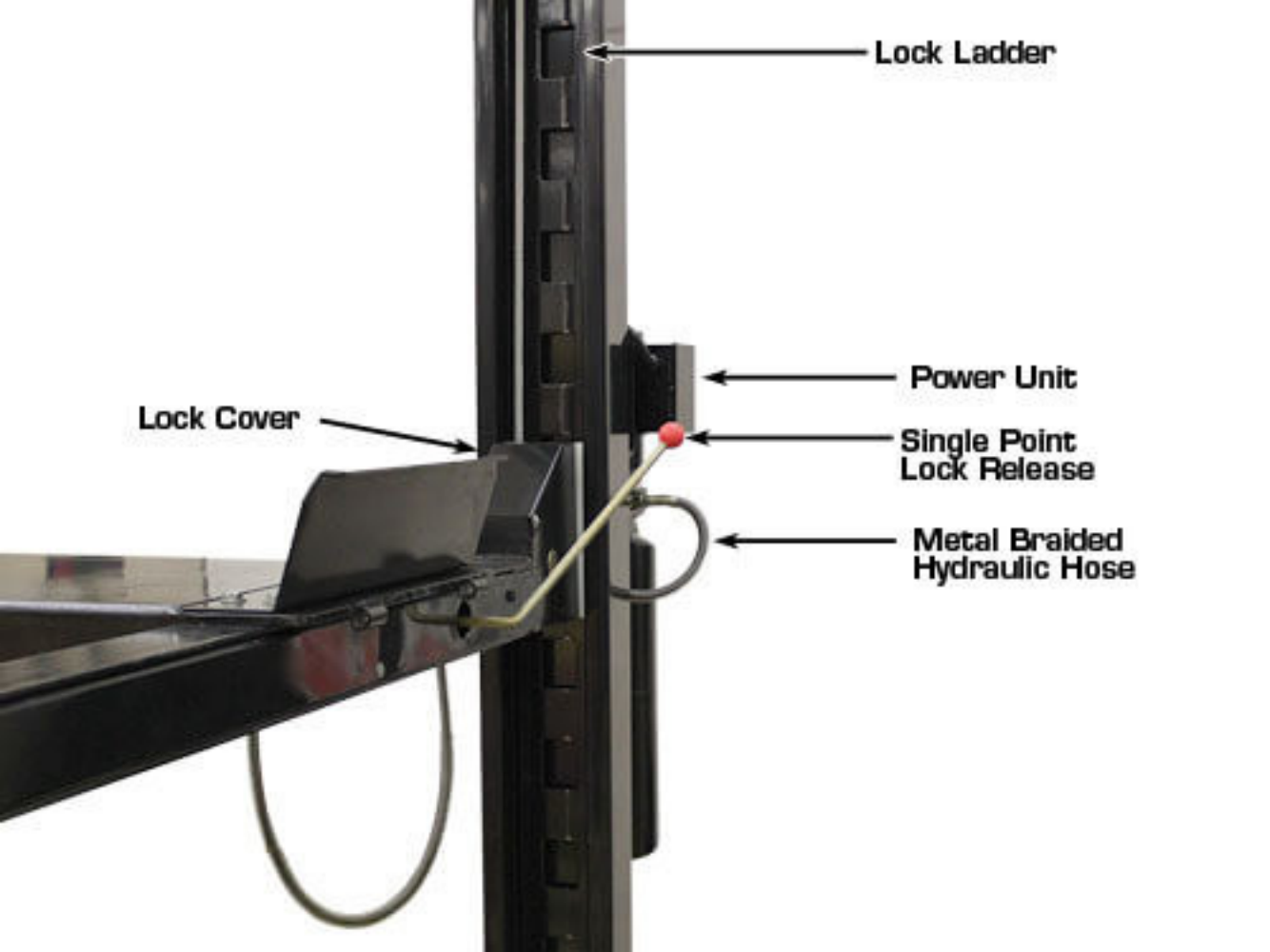

Lock Ladder

Lock Cover

Power Unit

Single Point
Lock Release

Metal Braided
Hydraulic Hose

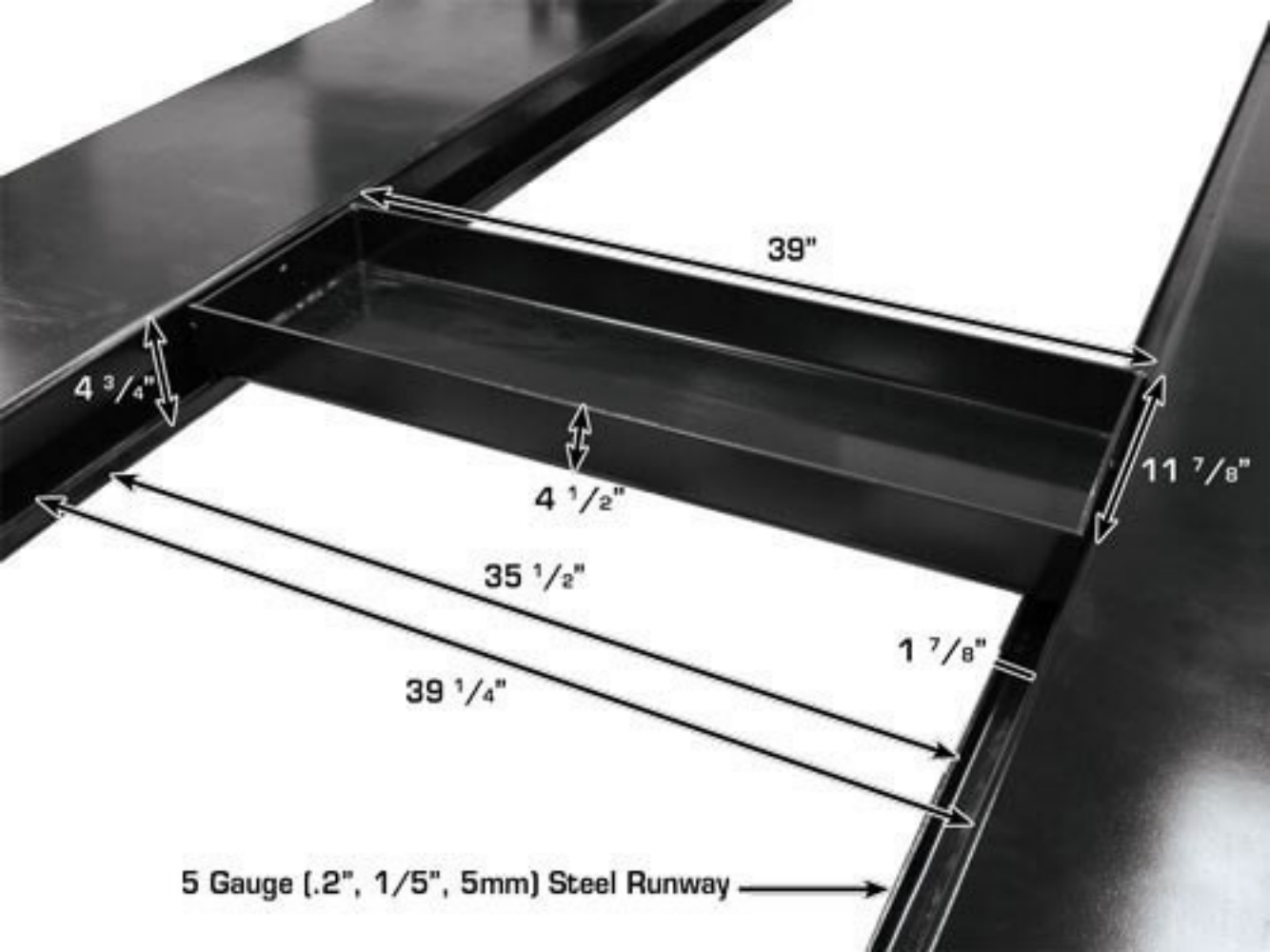

39"

4 ³/₄"

11 ⁷/₈"

4 ¹/₂"

35 ¹/₂"

1 ⁷/₈"

39 ¹/₄"

5 Gauge (.2", 1/5", 5mm) Steel Runway

Rubber Wheel Chocks (Included)



Includes 4 Drip Trays



39"

24"

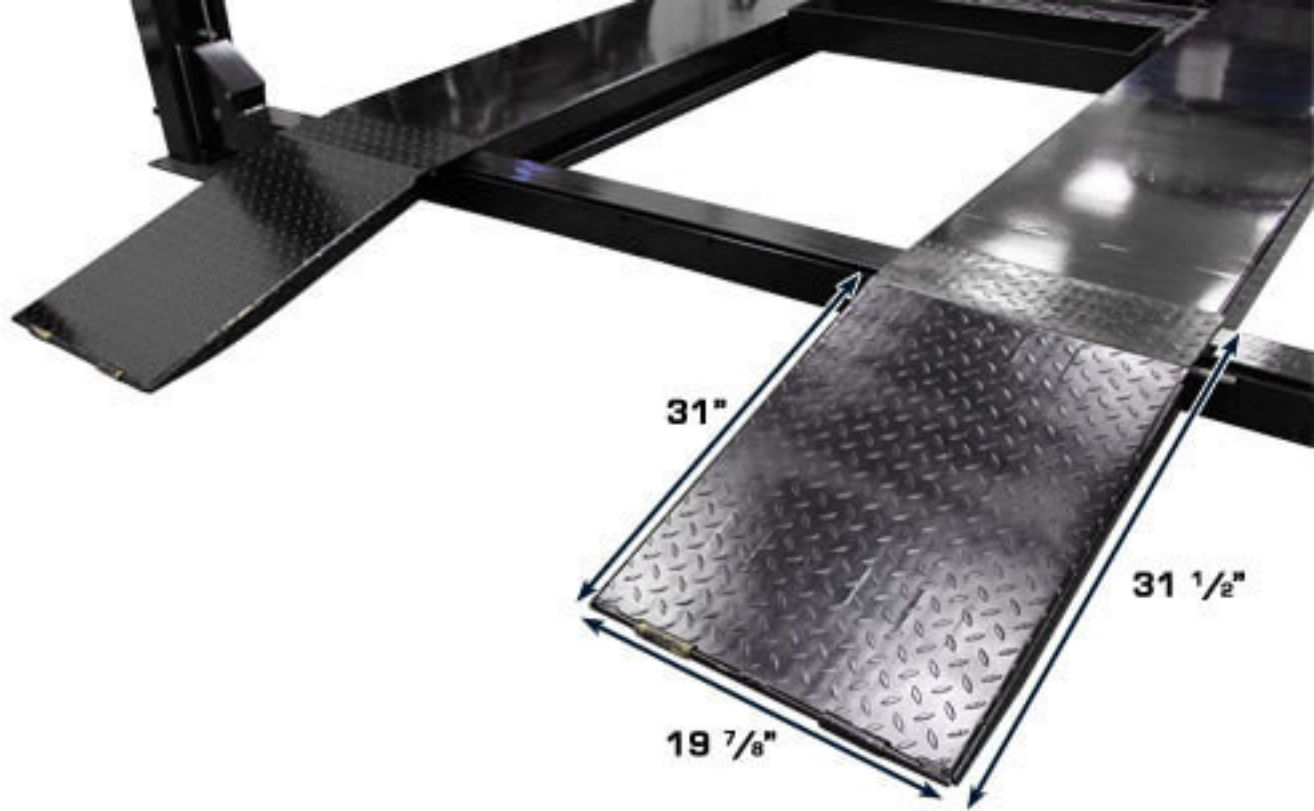

**Approach Ramps
Are Included**

Atlas Garage Pro 9,000
Four Post Lift Ready to Ship



Shipping Weight: 2,300 LBS.

Optional
Manual Operated
Pro Jack 4500

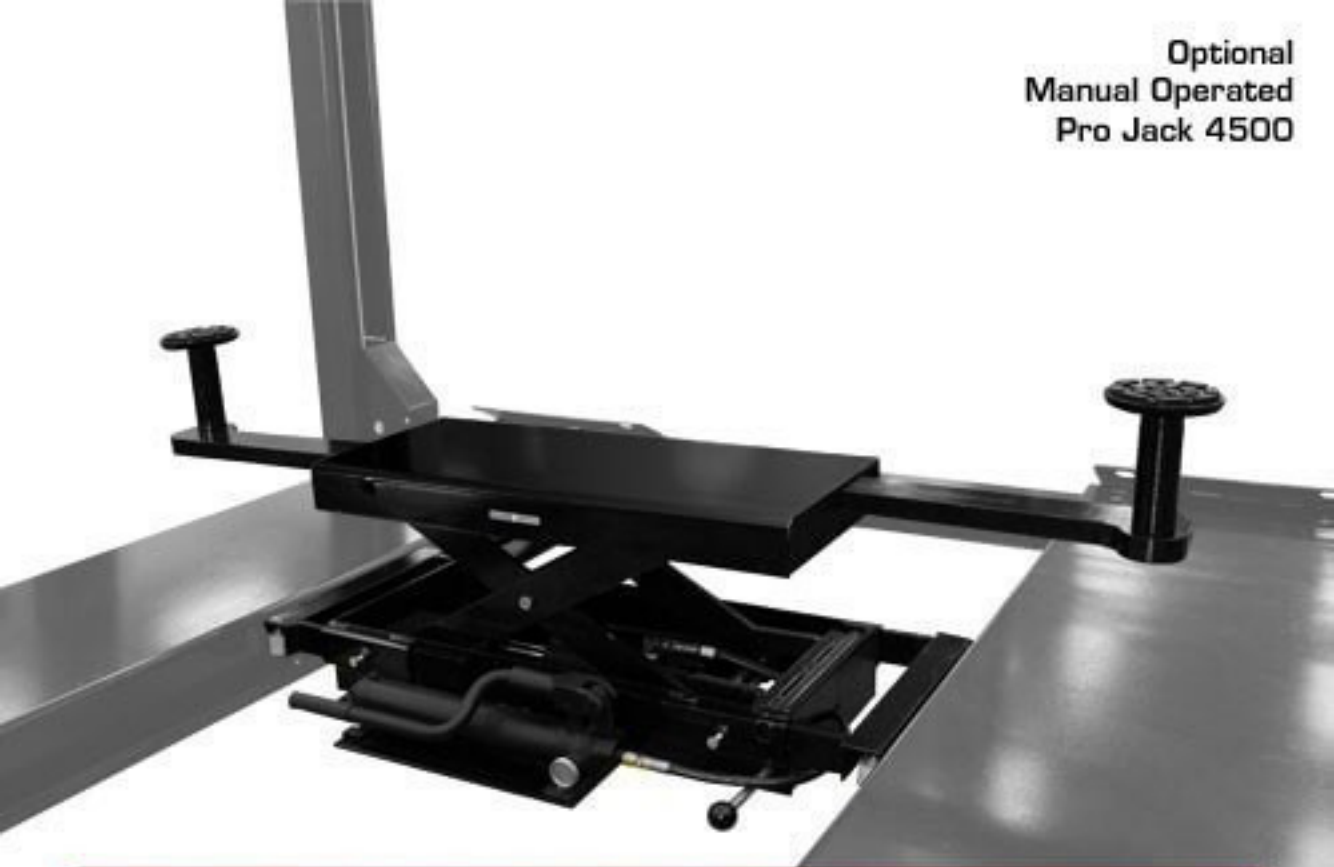

OPTIONAL EQUIPMENT

Optional Atlas RJ6000
Rolling Jack



OPTIONAL EQUIPMENT

**WE STOCK HUNDREDS OF PARTS!
CALL US FOR DETAILS**

Hydraulic Cylinder

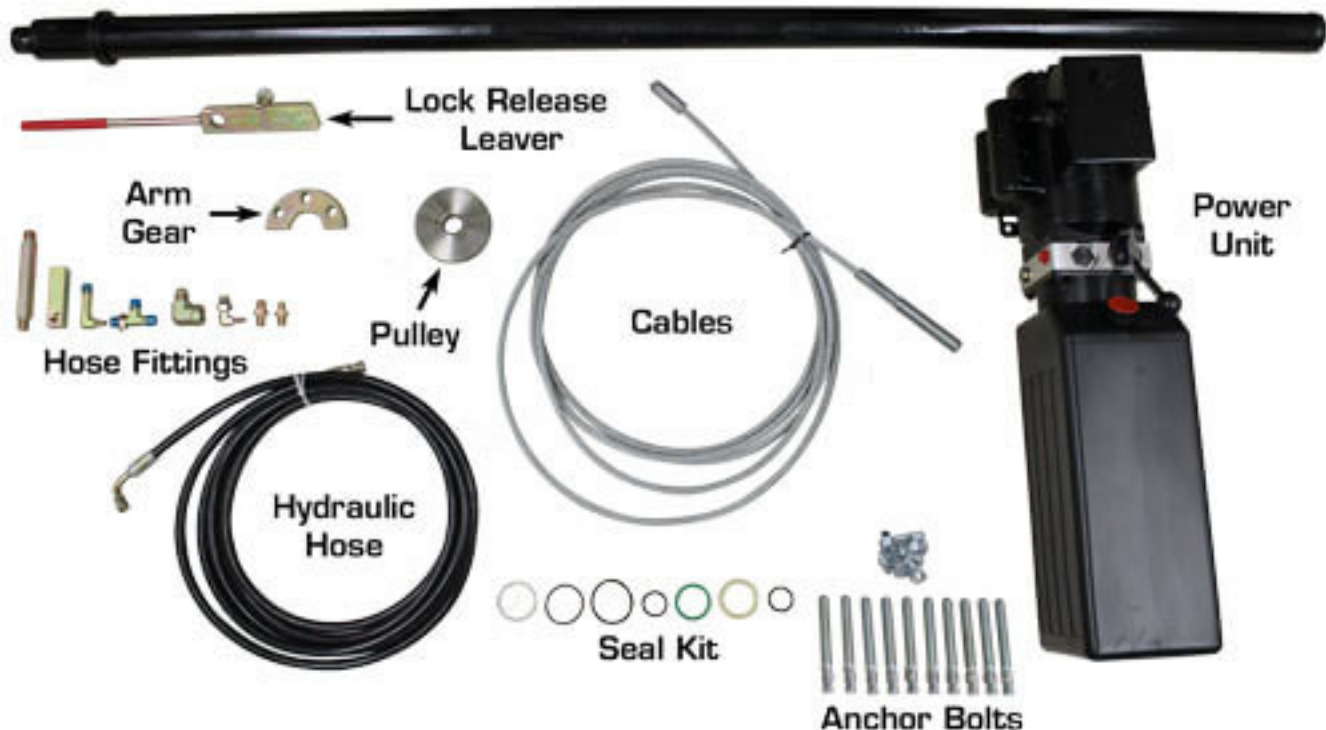



GREG SMITH
We have a fully stocked parts room to support our products!

